

**HMI** Hoyme Manufacturing Inc. **Special Note:** Circuits are colored for clarification only and are not necessarily those found in actual installations.

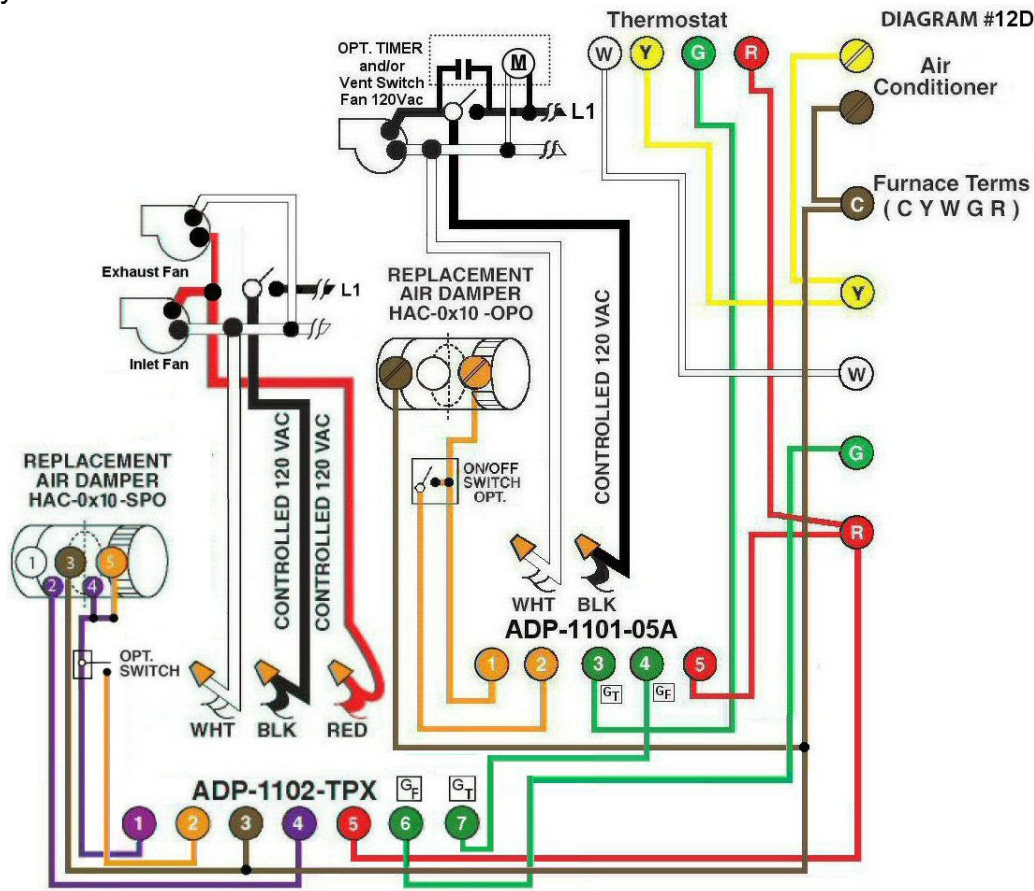

**Diagram #12D:** Forced Air Furnace having a regular replacement air supply duct with an inlet damper and an exhaust fan controlled by a designated ventilation switch. In addition, a special Replacement Air supply duct equipped with a Power Open Damper with End Switch, a Booster Inlet Fan and a High Volume Exhaust Fan.

1. Replacement Power Open Damper (HAC-0x10-OPO) where "x"= diameter.
2. Ventilation Switch to supply Controlled 120Vac to furnace area.
3. Relay Adaptor (ADP-1101-05A) to function as a control centre for regular ventilation.
4. Power Open Damper with an End Switch (HAC-0x10-SPO) INTERLOCKED to an Inlet Fan to supply extra replacement air for a high volume Exhaust Fan.
5. Interface Relay Adaptor (ADP-1102-TPX) acts as a control centre for the extra replacement air.

OPERATION:

1. Thermostat does not control the dampers. (If required, go to Diagram #12D1)
2. The designated **Ventilation Switch** simultaneously turns on the Exhaust Fan, the Furnace Fan and opens the Replacement Air Damper.
3. **Optional on/off Switch** connected between #1 and #2 of the Adaptor 1101-05A or 1102-TPX allows full control of the Replacement Air Dampers to open as required.
4. **In addition**, the high volume exhaust fan switch signals the adaptor (ADP-1102-TPX) to start the furnace circulation fan and open the extra replacement air damper.
5. After the extra **Damper with End Switch** proves to be open, both the **Inlet Booster Fan** and the high volume **Exhaust Fan** turn on. The Fans are, therefore, **Interlocked** to run only after the inlet damper is open for replacement air.

**Option:** Consider an Inline electric heater with an airflow switch to temper the incoming cold air.  
Additional Colored Wiring diagrams are shown on the web at [www.hoyme.com](http://www.hoyme.com)