

**HMI** Hoyme Manufacturing Inc. **Special Note: Circuits are colored for clarification only and are not necessarily those found in actual installations.**

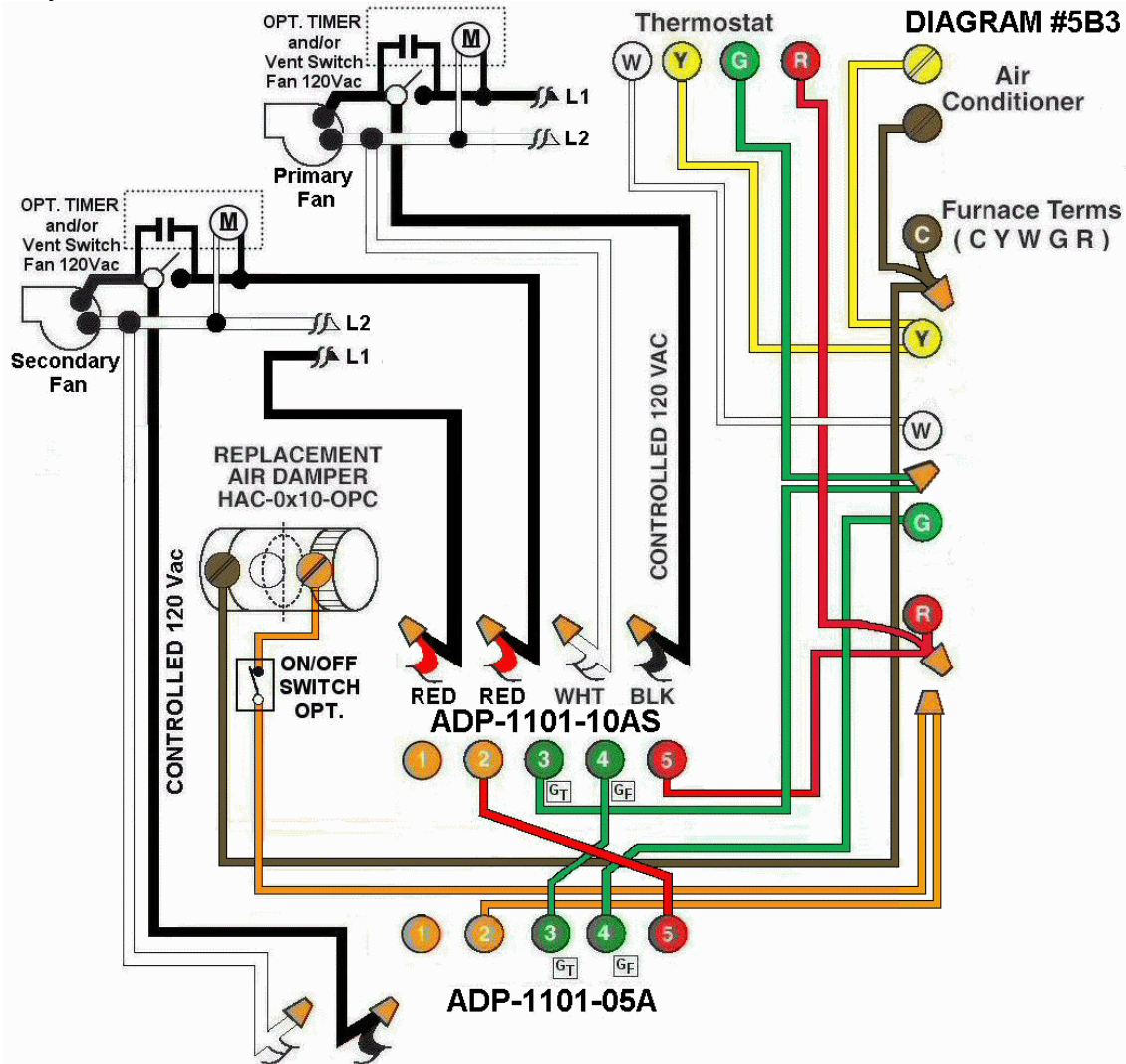

**Diagram #5B3:** Forced Air Furnace having one **replacement air** supply duct together with **two exhaust fans**, one Primary that overrides the secondary, both controlled by **two interlocking** relay adaptors, one being **ADP-1101-10AS** and the other **ADP-1101-05A**.

1. A Replacement Air Damper, Power Close (**HAC-0x10-OPC**);
2. **Two Ventilation Switches** that supply both live and controlled 120Vac to the furnace area;
3. **Two Relay Adaptors interlocked**, one being (**ADP-1101-10AS**) and the other (**ADP-1101-05A**). Both function as control centers to open the replacement air damper by **either the primary or secondary ventilation fan switch**.

OPERATION:

1. Either **Ventilation Switch** simultaneously turns on the Exhaust Fan, opens the Replacement Air Damper and turns on the Furnace Fan.
2. The **Secondary Fan cannot operate** while the **Primary Fan** is on.
3. **Optional Switch** (i.e. toggle switch) allows full control of the Replacement Air Damper to open separately provided it is a **Power Close** type Damper.  
(For Power Open damper see, Diagram #5B2)

**N.B.** Replacement Air Damper is not affected by the 'Manual' setting of the furnace fan nor is the Air Conditioner affected in any way.

Additional Colored Wiring diagrams are shown on the web at [www.hoyme.com](http://www.hoyme.com)