

Installation Instructions for **HMI** HOYME Adaptor 1102-TW5 24Vac/120Vac Controlled Voltage to Switch 24Vac

Installation Of This Adaptor Shall Be In Accordance With The Requirements Of the Authorities Having Jurisdiction.

Refer also to HOYME Installation Instructions: Replacement/Ventilation Air Control Damper – HAC-0x10-OPC/PO; ADP-1101-05A; ADP-1102-TWP.

ADP-1102-TW5



4" x 5" x 2 1/2"
101 x 127 x 64 mm



This Adaptor **ADP-1102-TW5** is an automatic relay control switch specifically designed, but not limited, to accommodate **two separate exhaust fans** in a dwelling interconnected to **one furnace** having a **replacement air duct** and (if used) a replacement **air damper**. A controlled 120Vac signal from one exhaust fan and/or a controlled 24Vac signal (or dry contacts) from a second exhaust fan will simultaneously turn on the furnace circulation fan and open the replacement air damper. **If the damper is to also open during furnace firing, go to Installation Instructions for ADP-1103-TW5.** These installations will not affect the operation of the furnace or Air Conditioner.

Fitness of this Adaptor/Damper combination, to satisfy air supply requirements for fuel fired appliances during operation of the interconnected exhaust fan(s), shall be investigated by the enforcing authorities.

Air intake duct installation shall be in accordance with: In Canada - CAN/CSA B149 & B139;

In the USA – ANSI/NFPA 54, 2006, ANSI Z223.1 and/or local codes including local codes relating to ventilation air duct installation.

I.D.: ADP-1102-TW5

One Relay DPDT: Relay Coil -120Vac.
One Relay DPDT: Relay Coil - 24Vac.
All Contact Points are 24Vac - 5 Amps.

- Adaptor line voltage leads, connected to the 120Vac exhaust fan controlled line, shall be suitably cabled, fastened and enclosed in suitable raceways.

- Refer to local and applicable codes.

- Always conduct a thorough check-out after installation is complete.

- Affix appropriate labels and follow instructions and warnings on each label.

Connecting the Adaptor ADP-1102-TW5 to a controlled 120Vac Designated Ventilation Exhaust Fan circuit and heating appliance.

1. Turn off electrical power supply to exhaust fan circuits and to the furnace.

2. Connect the controlled 120Vac exhaust fan circuit to the Black and White adaptor leads as per wiring diagram. Follow applicable codes.

3. Connect **Adaptor terminal #5** to the **furnace terminal 'R'** (24 Vac).

4. (a) Disconnect the thermostat wire '**G**' (if used) from the furnace terminal '**G**' and connect it to the Adaptor terminal **#3(G_T)**.

(b) Connect Adaptor terminal **#4(G_F)** to the furnace '**G**'.

5. Turn on the power supply to both the furnace and to the exhaust fan. Turn on the exhaust fan which will simultaneously turn on the furnace circulation fan.

ADP-1102-TW5

Connecting an exhaust fan with (a) controlled 2C-24Vac signal or (b) using dry contacts, to connect to the Adaptor 1102-TW5.

6. Turn off the power supply to both the furnace and the exhaust fan.

7. (a) Connect the controlled 2C-24Vac signal from the exhaust fan to Adaptor #6 & #7.

(b) **If using dry contacts**, connect one wire to Adaptor terminals #7 and the other wire to furnace terminal 'C', and **add a jumper wire** between Adaptor Terminals #5 & #6.

8. Turn on the power supply to both furnace and exhaust fan. Turn on the exhaust fan switch which will simultaneously cause the furnace circulation fan to run.

Connecting a replacement fresh air damper (if used) to open simultaneously with either exhaust fan running.

9. Turn off the power supply to the furnace.

10. Install a Hoyme 'HAC' 2C-24Vac motorized fresh air control damper to the duct as per instructions supplied with it. Satisfactory operation of the damper is recommended before fastening to the fresh air duct.

(a) For a **Power Open** damper, connect one damper wire to **Adaptor terminal #1** and connect the other damper wire to the furnace terminal '**C**'

(b) For a **Power Close** Damper, connect one damper wire to **Adaptor terminal 2** and connect the other damper wire to furnace terminal '**C**'.

11. Turn on the power supply to the furnace. If the damper is a **Power Open** type, it will remain **closed** at this time. If damper is a **Power Close** type, it will **close** at this time.

12. Turn on either exhaust fan. The exhaust fan(s), the furnace circulating fan and inlet damper will operate simultaneously.

Schematic Wiring Diagram of Adaptor ADP-1102-TW5

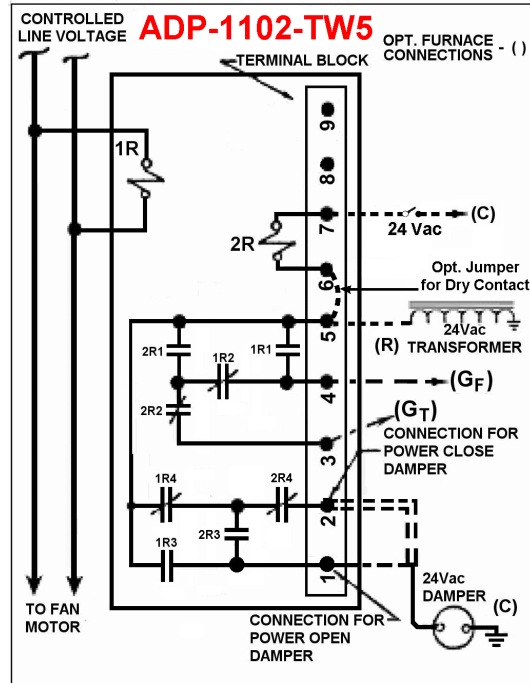

Note:

This marking is also on label to be affixed adjacent to appliance wiring diagram. Additional wire shall be of the same size as originally used when completing electric circuits.